

# Air Eco<sub>2</sub>nomy<sup>®</sup>

The optimal product for every wish and requirement

## GEA Air Handling Units

GEA Air Treatment | Versatile, flexible and efficient climate-control solutions





## Air Eco<sub>2</sub>nomy

# The signs of the times are clear

Air Eco<sub>2</sub>nomy is more than just technology. It is an attitude which creates future-fit values: quality of life for people, climate and environmental protection, and security for architects, planners, investors, and companies.

With Air Eco<sub>2</sub>nomy, GEA Air Treatment offers you climate-control solutions distinguished by economical and ecological maximum efficiency.

As architect, planner or investor, today you must take many factors into account before deciding on a certain air technology. Aside from price and quality, rapid product configuration, short delivery times, simple assembly and servicing as well as high energy efficiency have long been important issues. Especially the life cycle costs, i.e., the costs incurred over the entire service life of the technology, have become a significant decision criterion.

Under the Air Eco<sub>2</sub>nomy slogan, GEA Air Treatment offers you comprehensive, holistic air treatment developments which cover all demands for efficient solutions. The technology leader's innovations are economically and ecologically convincing, do the task reliably and facilitate your work.

The versatile usages of GEA air handling equipment provide a convincing example of these benefits. These systems are characterised by customised HVAC and air treatment for the greatest possible reduction of energy consumption over the entire service life of the equipment: it pays for itself in cents and euros, comfort and work efficiency. The solutions set new standards for sustainability and perfected system integration in buildings of all types.



## GEA Air Handling Units

# Optimised for every application

The requirements are not always identical: with appropriately designed product lines, GEA Air Treatment satisfies every wish.

### Overview of GEA central air handling:

- Six different product lines for individual demands
- Large range of standard to high-end solutions
- Modular and compact air handling units

If room air conditions remain within a narrow comfort zone, we feel a sense of well-being. However, the climate in rooms is influenced by many factors and the requirements on these conditions can be very different, depending on the type of room or its use. A regular supply of fresh air is important. This job is satisfied by GEA air handling units. Furthermore, these units also create and maintain a defined state of room air. While for some applications only an exchange of air is needed, for others the requirements increase with respect to temperature, humidity and purity of air. Modular units permit you to freely select components and functions and allow for flexible adaptation of details for various applications. Compact units are optimised to the application, delivered equipped with highly efficient heat recovery systems and ready for connection to integrated controls.

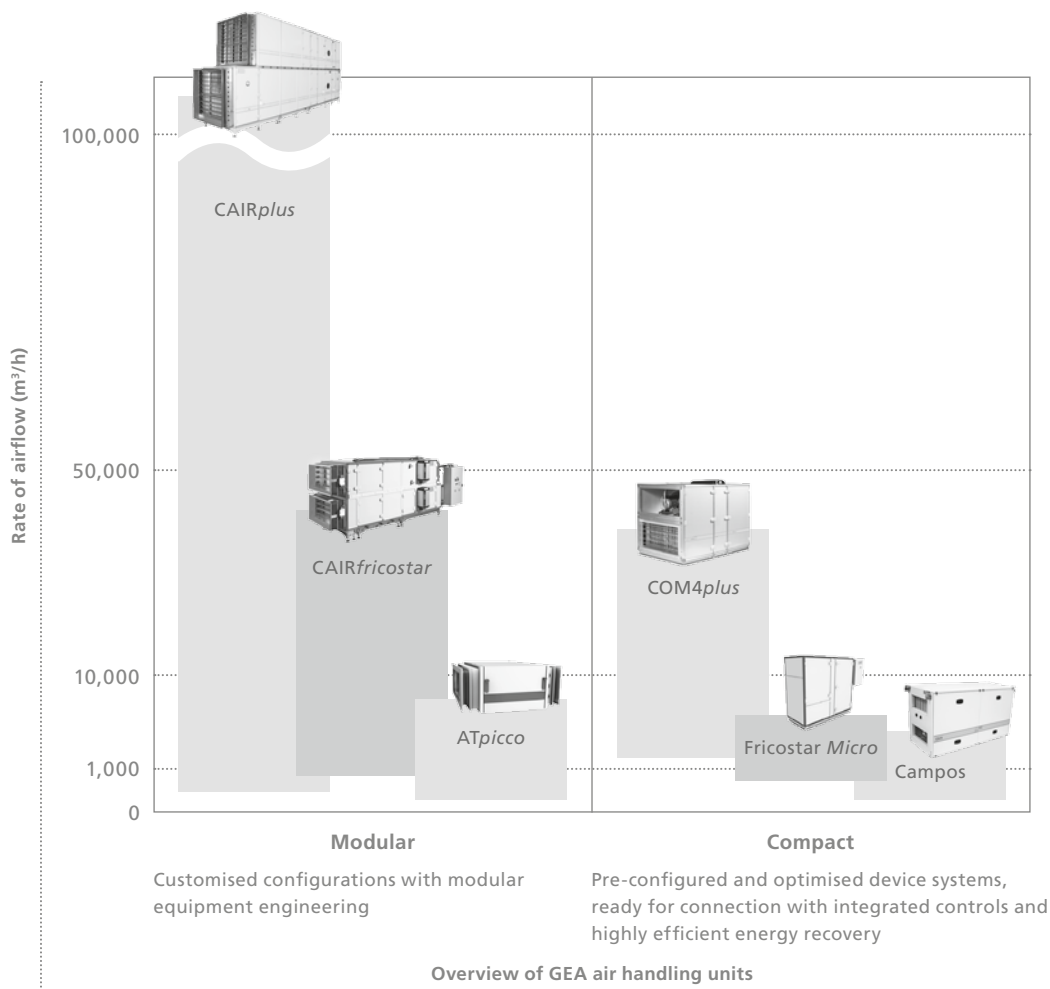

### GEA Air Handling Units:

- **CAIRplus**  
High-end solution with maximum flexibility (model sizes, enclosure models, components, configurations, etc.)
- **CAIRfricostar**  
High-end solution for climate control of swimming pool and wellness areas
- **ATpicco**  
Full-value air handling device in low-profile design for mounting between ceilings
- **COM4plus**  
Compact universal system solution for diverse application areas
- **Fricostar Micro**  
Space-saving device for climate control of smaller swimming pools – also for retrofitting
- **Campos**  
Space-optimised system solution for climate control in residential and educational buildings

# Configurable with modules – and unlimited possibilities

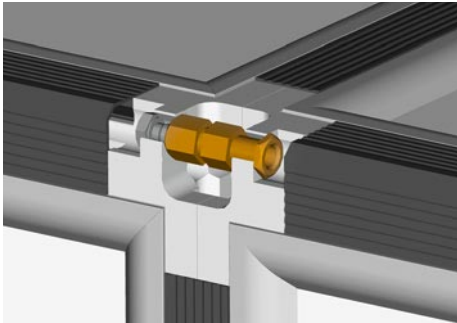

The intelligent solution for unit connections: the especially developed partition joint connector which disappears behind a protective cover.

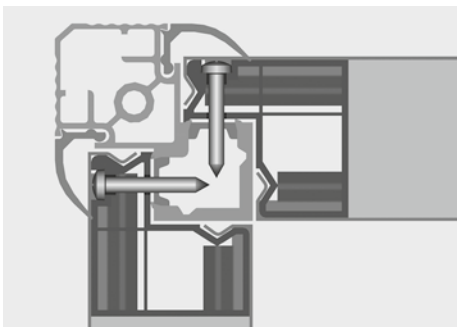

The enclosure has a completely smooth interior and is thus easy to clean. This creates optimal prerequisites for hygienic operation according to VDI 6022, VDI 3803 and DIN 1946T4 standards.

### Advantages of GEA CAIR*plus*:

- Individual customised units according to your wishes
- Low investment, operation and maintenance costs
- Modular construction and a complete system solution
- Durable quality components
- Secure function for all climatic conditions
- Large number of available components
- TÜV and ILH tested

The GEA CAIR*plus* (CAIR = Customized Air) range of models supports you in meeting your customer requirements in the best way possible. The new generation offers a large number of model sizes. Whether an interior or exterior unit, vertical or horizontal installation, one over the other, behind each other, or next to each other – almost every type of installation is available.

### Great diversity of models

The enclosure design of the GEA CAIR*plus* units is a combination of aluminium profiles and panels. In special cases, this especially sturdy construction even allows complete assembly on location. All panels, doors and flaps can be mounted and dismantled from the outside. In addition, a thermally separated design is also offered, providing the possibility – apart from a completely separation model – of thermally separating only the enclosure parts endangered by condensation.

### Hidden technology, hygienic operation

The design of the GEA CAIR*plus* air handling units optimally combines stability and functionality.

Panel screw connections are made directly with the stable frame profile. The partition joint allows the connection of the delivered units at the construction site with only a few manual operations. The connection can be made alternatively from the inside or outside. The partition joint has no influence on the unit length. The cover strips, simple to disassemble with the screws lying on the outside, serve as seam sealing on weatherproof units and simultaneously ensure easy accessibility. No panel screws are employed inside. No frame parts protrude, ensuring an optimal prerequisite for hygienic operation. Flexible in design, the construction permits a high insulation class (T2 / TB2) for minimal leakage (L1 / F9) and high stability (D2) according to EN DIN 13779.

GEA CAIR*plus* units are available with integrated cooling and control technology. Furthermore, different heat recovery systems are available. Our gratis Lplus software will help you with your optimal configuration of the units.

### Material qualities

For the enclosure walls and profiles, the following material qualities can be freely combined with each other:

Wall inside / outside	Profile
Aluzinc 185 <sup>1)</sup>	Aluminium, natural finish
Coil-coated	Powder-coated
Stainless steel V2A	
Stainless steel V4A	

<sup>1)</sup> Aluzinc 185 with anti-fingerprint finish conforms to the quality of coil-coated material with corrosion protection Class III according to DIN 55928 Part 8 and is suitable according to the RLT 01 and VDI 3803 guidelines for the exterior shell of weatherproof units.



### Unit cross-sections and air volume flow

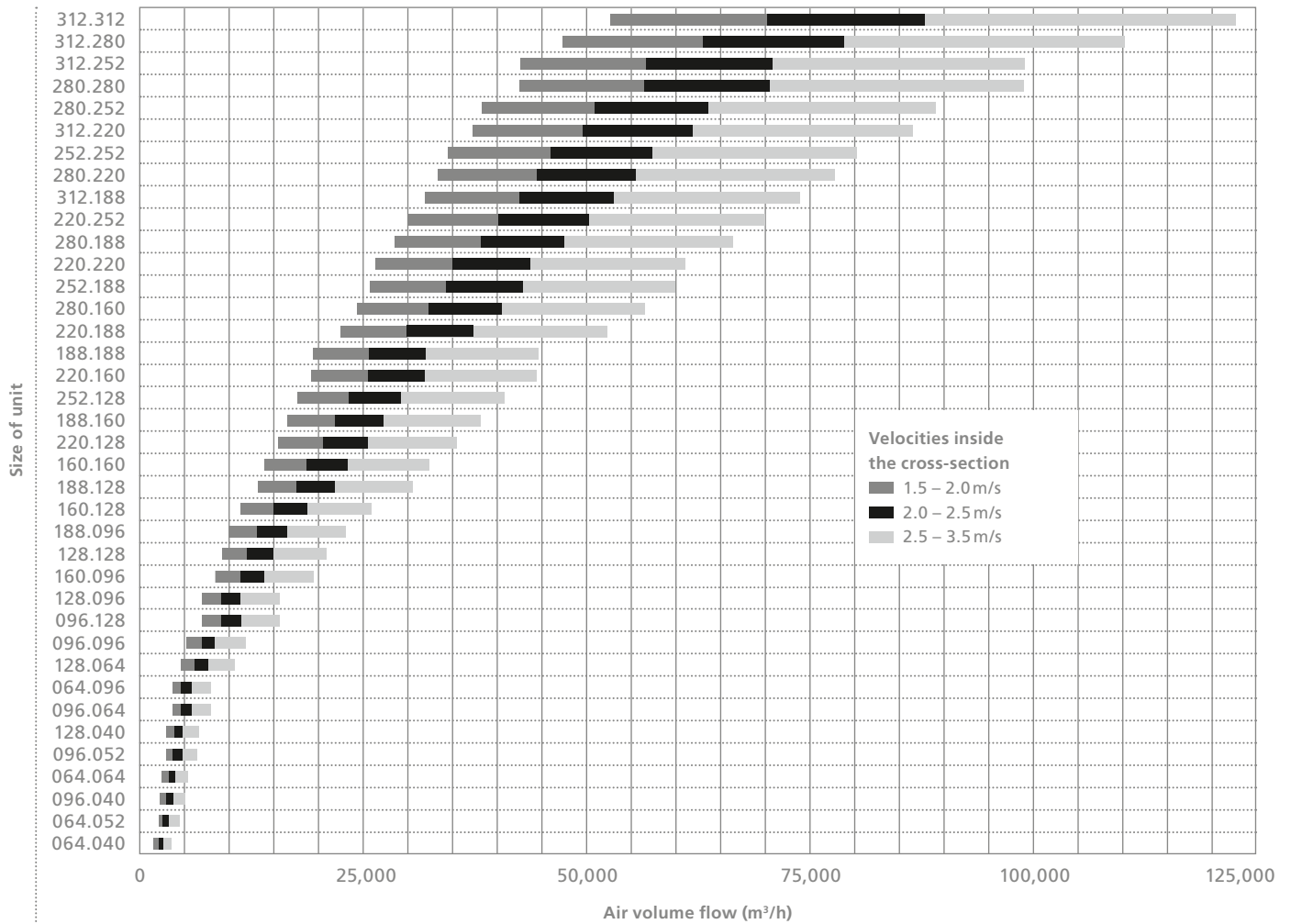

The unit cross-section results from the specification at the left edge. Here the cross-section width x height with dot division is separately specified in cm. With an extensively varied grid measurement and thus many available versions, a suitable type of unit can be selected for almost every application.

## Swimming pool dehumidifiers with heat recovery



The GEA CAIR*fricostar* units are based on proven and reliable CAIR technology and equipped with resource-friendly technology – optimally suitable air handling units for dehumidification and climate control of swimming pool areas of every type and size.

### Advantages of GEA CAIR*fricostar*:

- Highly efficient heat recovery
- Low investment, operation and maintenance costs
- Modular construction and complete system solution
- Durable quality components
- Secure function for all climatic conditions
- Constant performance in entire temperature range
- High efficiency (> 82%) and low energy consumption
- Performance ratings for all pool areas available

Swimming pools are a power-engineering challenge. With GEA CAIR*fricostar*, dehumidification and climate control are combined in an especially economical manner.

If you not only want to dehumidify a swimming pool area but also desire an effective energy-saving climate control system with full comfort, then the GEA CAIR*fricostar* series is for you. Operating costs are kept within reason with a regulated supply of fresh air in connection with various heat recovery systems, and a heat recovery rate of up to 82%. GEA CAIR*fricostar* can be universally employed for private swimming pools, wellness or therapy facilities and commercial fun pool centres.

### Corrosion protection plus hygiene – tested according to VDI 6022

GEA CAIR*fricostar* units excel through modular design and are also suitable for subsequent installation in small openings. The modular technology makes it possible to create an individual unit for practically every application. The hygiene standard of the entire series complies with VDI 6022 standards and is even suited for use in hospitals as well as rehabilitation and therapy centres. The design of the GEA CAIR*fricostar* units prevents formation of a cold bridge or condensation water, thus ensuring long equipment life. Furthermore, the units can be delivered in three corrosion protection classes:

- Corrosion protection class K: standard version for use in normal swimming pool areas
- Corrosion protection class H: designed for increased requirements in chlorine or saline air (sea water and brine spas up to 3% brine)
- Corrosion protection class P: designed for very high requirements for use in aggressive environments such as thermal spas and a salt content of more than 3%.

### Optimally controlled

A perfected DDC control automatically determines the favourable method of operation and supports the economical operation of the central air plant. Interfaces to all prominent building management systems present no problem for GEA CAIR*fricostar*. Systems such as BACnet, LON, MOD, OPC, OSPA Blue Control, In-ternet or SMS communication make connections simple.

### Modular design – GEA CAIRfricostar

- GEA CAIRfricostar air handling units with heat pump unit types CAU, CAM, CMU, CMP, CPP  
Heat recovery with ECOSTAT heat pipe or ECOPLAT TWIN double-plate heat exchanger and additional heat pump
- GEA CAIRfricostar air handling units without heat pump unit types CWP, CWR  
Heat recovery without additional heat pump



### Compact construction – GEA Fricostar Micro

- GEA Fricostar Micro CAC with heat pump
  - GEA Fricostar Micro CWC without heat pump
- Owing to smaller dimensions (40% smaller length than module units), especially suited for small technical rooms, upgrading or renovations. The features conform to the modular units.

### Unit distribution relative to the surface of water and air volume flow

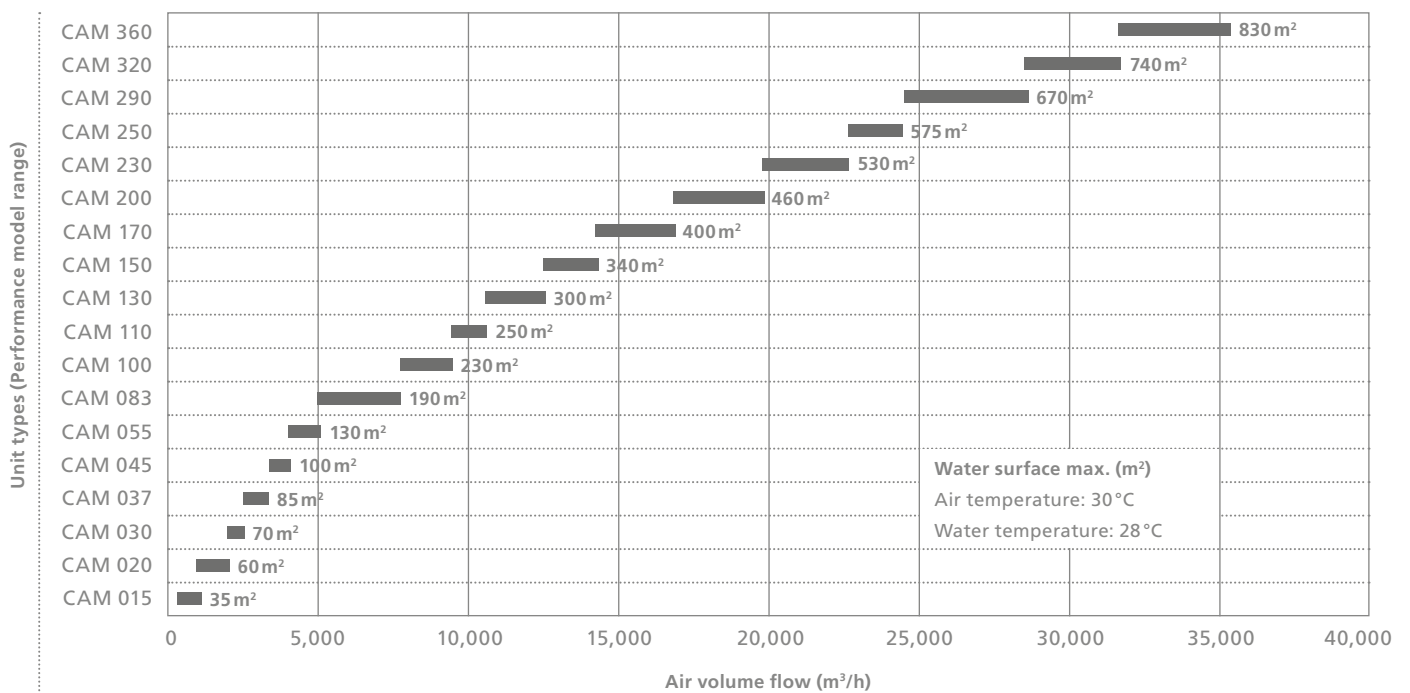

## GEA COM4plus

# Completely assembled – and everything inside



The GEA COM4plus offers you a compact solution which unites all the required functions of central air handling into one unit. Based on the CAIRplus design, those outstanding characteristics are also employed in the COM4plus units.

The GEA COM4plus offers you a preconfigured full-featured compact unit with components optimally harmonised with each other, ready for connection and housed in an enclosure. The system includes high-efficiency energy recovery features, continuously variable air volume flow control over plug fans with integrated frequency converters, as well as a mechanical quick-fit connector and handy modules for rapid installation. The air volume flow can be dosed by demand with the GEA COM4plus, while the integrated energy recovery reduces consumption of resources. Up to 90% of the thermal energy contained in the exhaust air can be resupplied to the building.

### Advantages of GEA COM4plus:

- Rapid, simple unit configuration in a few steps
- Short delivery times
- High quality, all features without additional charge
- Indoor unit as well as units for exterior use available
- Complete wiring or ready-to-install and plug-in (for divided units)
- Commissioning: switch on – finished!
- Simple servicing according to need
- Low operating costs over entire service life

The functional principle of GEA COM4plus harmonised to changing requirements is supported by a comprehensive and intelligent control system. It purposively monitors all parameters, functions and processes, thus always ensuring an ideal relationship of power demand and power consumption.

Existing space may be optimally exploited by the compact construction type of GEA COM4plus. The assembly itself can be carried out in the smallest rooms, since the equipment can be divided into sections. The basic unit is available in nine model sizes and optionally extendable. This means short delivery times and a well thought-out system for assembly and commissioning. The weatherproof enclosure furthermore also allows outdoor installation.

Whether an old building or a new construction, a renovation or a new planning project – GEA COM4plus is up to all requirements of air conditioning in buildings.

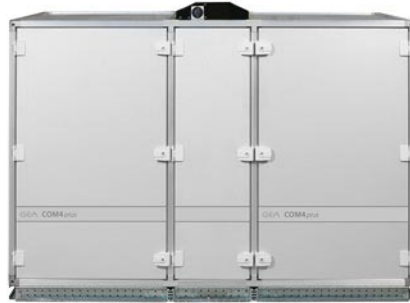

### All-inclusive – GEA COM4plus

- Highly efficient energy recovery system by means of rotational heat exchangers
- Integrated control system
- Compact fan unit with integrated frequency converters
- Optimally designed ventilation cross-section and incoming-air lengths permit especially compact construction
- Dampers integrated in the casing
- Louver drives arranged outside the airflow for optimal hygienic conditions
- Directly powered, variable-speed motors

### Unit sizes and air volume flow

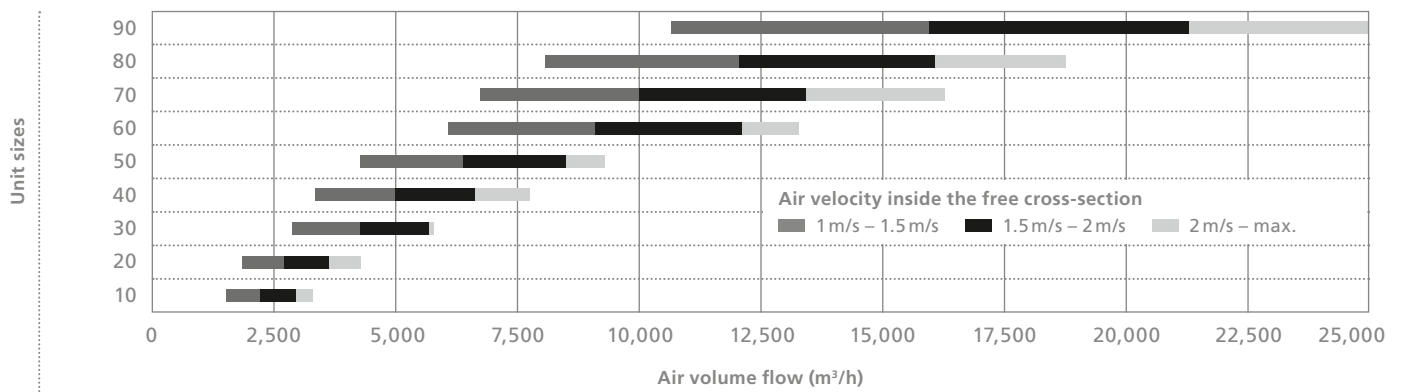

## GEA ATpicco

# Central air handling in the smallest space



The flat unit GEA ATpicco offers tailor-made climate control for small rooms

GEA ATpicco is an air handling unit which demonstrates its advantages in the smallest spaces.

Yet it keeps the promise of absolutely fully fledged. Because despite its small dimensions, it has the complete complement of functions you expect from an air handling unit. Noise emissions are as small as with a larger unit. Furthermore, the heat brought into the room can be economically recovered with integrated heat recovery.

### GEA ATpicco offers greatest flexibility

The intelligent concept of the GEA ATpicco offers you greatest flexibility in planning and assembly with optimally graded modules. You have a comprehensive selection: directly or belt driven, highly diverse heating units, coolers or fans, intake and mixing chambers – the entire palette of combinations.

### Advantages of GEA ATpicco:

- Volume flows up to 5,500 m<sup>3</sup>/h
- Space-saving, flat construction (355 mm or 450 mm high)
- Multiple installation possibilities (ceiling, floor, wall)
- Complete variety of functions



GEA ATpicco permits hygienic, simple and safe servicing.

### Unit cross-sections and air volume flow

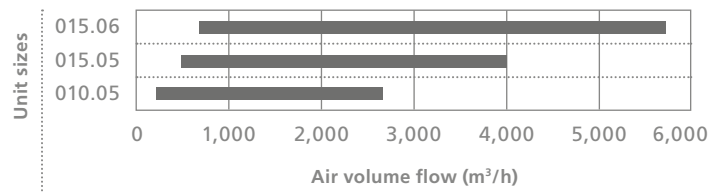

### The electrostatic filter as an additional function

An electrostatic filter for air handling units is available under the designation GEA Piccotron, which is especially designed for the continual cleaning of smoke and odours from the room air. This cleaner system combines the well known and proven filter technology of GEA Clarifair with the GEA ATpicco. Its use can eliminate 99.9% of tobacco smoke and other fine-particulate dust from the room air.

## GEA Campos

# The solution for controlled air handling

The jointless construction of modern buildings as well as environmental burdens increasingly require using highly efficient air handling units to prevent damage caused by humidity as well as to protect against noise and harmful substances.

Deficient air quality has a decisive effect on tiredness, headaches, breathing difficulties and skin irritations. With insufficient fresh air, our ability to concentrate also deteriorates.

With GEA Campos, the carbon dioxide content in for instance schools and others educational establishments can be significantly lowered through continual air exchange. Further areas of application of GEA Campos are office rooms in public and commercial buildings, passive and multi-family houses, apartments, fitness centres and event rooms, libraries and cafés.

GEA Campos units contain directly powered and energy-saving EC fans for quiet operation, highly efficient energy recovery with up to 90% efficiency by means of cross-counterflow plate heat exchangers as well as premium fine-particulate filters of class F6 and F8, which also ensure suitable air quality for allergy sufferers. The units are delivered as plug-and-play solutions with integrated controls which for example notify the requirement of filter replacement with a pressure differential display. Furthermore, GEA Campos is equipped with an integrated, motor-actuated bypass for fall and spring and for summer night cooling.

The GEA Campos unit casings is accessible from two sides and suitable for left or right assembly as well as a horizontal, vertical or a flat-lying layout of the equipment. Replaceable duct connections facilitate on-site ductwork.

High-tech in a small space: GEA Campos units contain directly powered energy-saving fans, heat recovery and a suitable control technology ex factory. Depending on the model, they offer a maximum rate of airflow of 750 or 1,500 m<sup>3</sup>/h supply air.

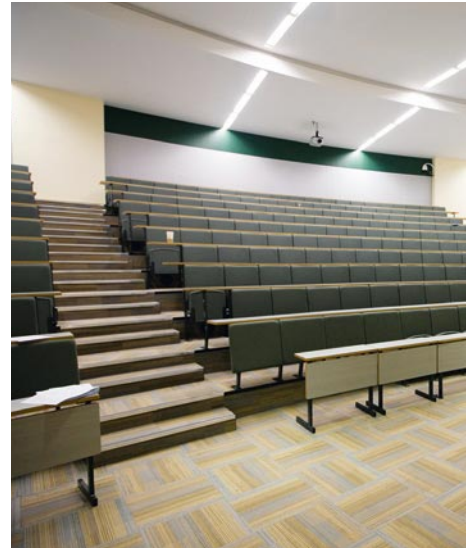

### Advantages of GEA Campos:

- Compact air handling unit for all seasons with all advantages of a full-value central air handling unit
- Ventilation with or without heat recuperation during fall and spring
- Summer night cooling in bypass operation
- Cooling with add-on modules
- Heat recovery with or without reheating in the wintertime



## GEA heat recovery

# Models for every requirement

Efficient heat recovery is one of the basic functions of GEA air handling units. Various model versions are available, depending on requirements.

A heat-recovery system must provide solutions to various requirements, depending on the building situation and the ventilation problems involved. Typical questions to be answered here: Are supply- and exhaust-air flows physically separated? Are there strict hygiene requirements? Is the exhaust air especially polluted?

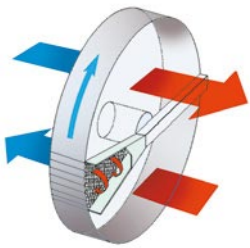

ECOROT – Rotational heat exchanger

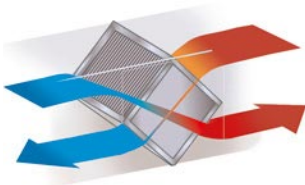

ECOPLAT – Plate heat exchanger

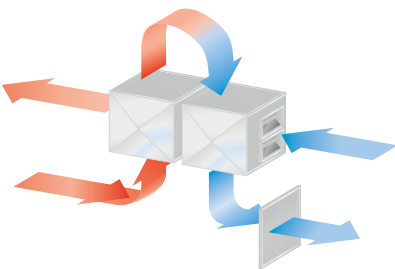

ECOPLAT TWIN – Double-plate heat exchanger

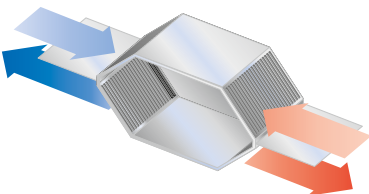

ECOPLAT Counter – Counterflow-plate heat exchanger

Depending on the requirement, GEA delivers the suitable heat recovery system:

### ECOROT – Rotational heat exchanger

- Heat recovery rate up to 85%
- Self-cleaning effect by counterflow
- Humidity transfer possible
- Power control with motor speed
- For large air volumes
- Low pressure loss

### ECOPLAT – Plate heat exchanger

- Heat recovery rate up to 70%
- No moving parts
- No intermixing of the air flows
- Power control with bypass

### ECOPLAT TWIN – Double-plate heat exchanger

- Heat recovery rate up to 80%
- No moving parts
- No intermixing of air flows
- Power control with bypass

### ECOPLAT Counter – Counterflow-plate heat exchanger

- Heat recovery rate up to 90%
- No moving parts
- No intermixing of air currents
- Power control with bypass
- For smaller air volumes

### ECOFLOW – Liquid-coupled heat exchanger

- Heat recovery rate of 50% to 80%
- Air currents can be spatially separated
- Also retrofitting in existing equipment
- Compact construction
- No intermixing of air flows
- Small space requirements

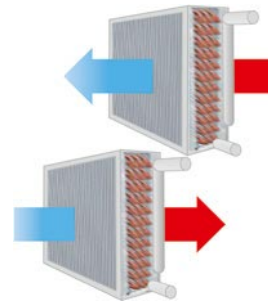

ECOFLOW – Liquid-coupled heat exchanger

### ECOSTAT – Heat pipe

- Heat recovery rate up to 60%
- No moving parts
- No intermixing of air currents
- Small space requirements
- Power control with bypass possible

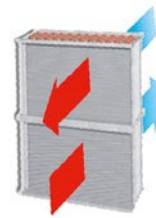

ECOSTAT – Heat pipe

## Availability of heat-recovery systems

Possibilities	CAIRplus	CAIRfricostar	ATpicco	COM4plus	Campos
<b>Heat recovery</b>					
ECOROT	●			●	
ECOPLAT	●	●	●	●	
ECOPLAT TWIN	●	●			
ECOPLAT Counter					●
ECOSTAT	●	●	●		
ECOFLOW	●	●	●		
<b>Control</b>					
MATRIX 4700	●		●	●	●
Other makes	●	●	●	●	

## GEA CAIRplus Air Handling Units with integrated cooling technology

# Complete from one source

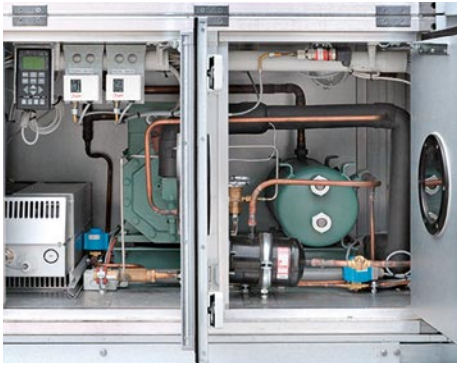

Integrated cooling and control technology means simplified engineering. The outlay for assembly and commissioning on location is clearly reduced.

In many situations it is advisable to use a GEA air handling unit with integrated cooling instead of external chillers. Our harmonised device concept also offers the right solution for every project. Customer engineering is not necessary with the one-supplier solution. There is no pipework outlay. At the same time you save valuable space and secure a high measure of energy efficiency for your customers.

### Integrated cooling technology in overview:

- Diverse areas of application: e.g., in offices, markets, and department stores
- No engineering required
- No pipework requirements
- High energy efficiency with heat recovery
- Air volumes from 3,000 to 35,000 m<sup>3</sup>/h
- Five model sizes one over the other
- Six model sizes side by side
- Optional adiabatic exhaust air humidification
- Control GEA MATRIX 4700
- Project-specific solutions possible

GEA CAIRplus air handling units with integrated cooling technology are to a large extent installed at the manufacturer's and delivered ready for connection. The outlay for installation and commissioning on location is correspondingly small. All components are optimally harmonised with each other. Apart from modern control technology, the units also provide highly efficient heat recovery.

Excellent reliability is achieved by direct evaporator technology with the refrigerant R 134a; the systems are also absolutely safe to operate at high outdoor temperatures. You have complete flexibility in the equipment configuration. Cooling output can be continually adapted to the actual cooling requirements. An adiabatic evaporative cooling can furthermore be optionally selected for minimised power requirements.

### Unit cross sections and air volume flow

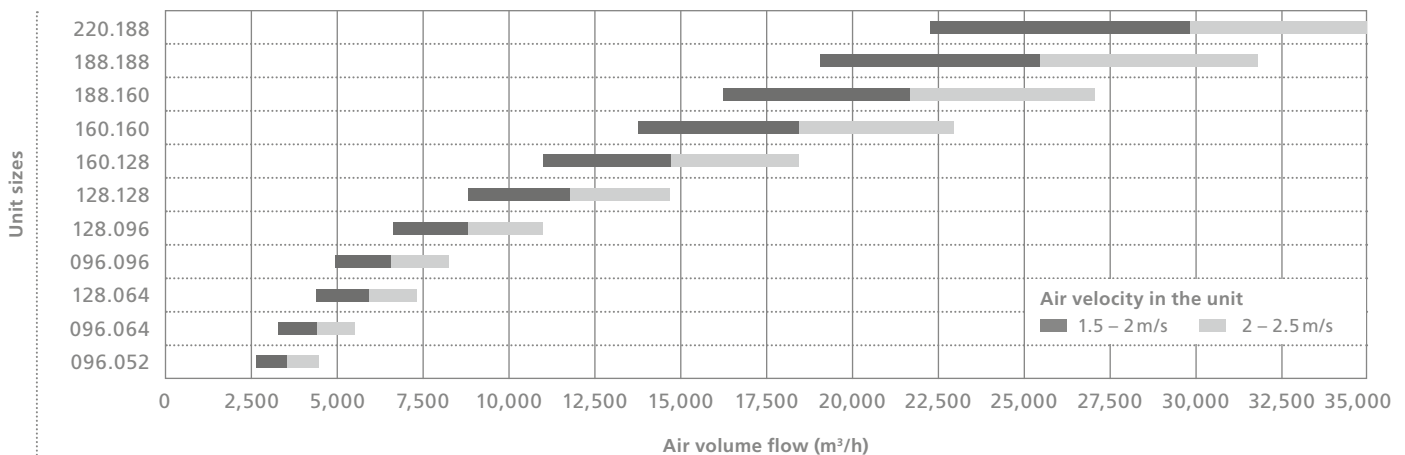

## GEA MATRIX 4700 – energy-optimised deployment

# And everything is optimally controlled

The concept of the compact control GEA MATRIX 4700 finally makes it possible for you to visibly install only those components in a room which are actually required to operate a central air handling unit. Simultaneously, the control electronics can simply be installed where sufficient space is available.

### However this is not enough:

- Perfect comfort and operational reliability are the focus of the automatic control and monitoring functions of GEA MATRIX 4700
- Whether speed control, temperature control, energy recovery or electrical heating – all functions are rapidly and reliability carried out
- Extensive monitoring functions such as PTC resistor protection for the fan motor, pump blocking protection, frost protection monitoring, v-belts and filter monitoring always ensure the best possible operational reliability
- Many functions such as the night-cooling function in summer, limit temperature control in heating operation, supply air/ exhaust air/ room/ cascading temperature control are implemented by this new control concept

Whether you prefer to use direct or belt-driven air handling units, CAIRplus, ATpicco, COM4plus or Campos: a special GEA MATRIX 4700 is always there to meet your needs and operate reliably.

### Everything for maximum quality

A modern test bench and software configurator are employed for the customer-specific programming, which guarantee faultless function and testing according to prevailing EN standards. Preset parameters with effectively stored limit values make the GEA MATRIX 4700 ready for operation immediately and minimise commissioning time. Only a few parameterisation steps are directly necessary at the LCD operating unit in order to prepare the air handling system for operation.

### LON connection to external BMS

A LON interface is optionally available for connection to an external building services management system. Whether in gastronomy, offices, laboratories, production rooms or ancillary sanitation rooms: you can always design your individual control program with the GEA MATRIX 4700.



### Comprehensive control possibilities:

- Versatile compact controls
- Control in various model capacity rating stages
- Bus interface to other units
- Plug-and-play functionality
- Energy-optimised unit operation
- Ready-for-operation units and competent service
- Global add-on modules
- LON connections
- Service tool available

## GEA *Lplus* software

# Designed to the point



### Advantages of the configuration software GEA *Lplus*:

- Individual configuration proposals
- Determination and output of component spacing, module arrangements, measurements and weights
- Calculation of life cycle costs (LCC)
- Simple handling
- Rapid, secure selection and planning
- Gain in time for other tasks
- Specification of energy efficiency classes (Eurovent and AC manufacturer association)
- Calculation methods regularly examined by Eurovent



The GEA *Lplus* configuration software covers all products of GEA Air Treatment. The gratis full version can be downloaded from the Internet ([www.gea-happel.de](http://www.gea-happel.de)) in the "Products" menu item, or can be requested from us.

GEA air handling units offer a tailor-made solution for every building situation. Selection and configuration of the right unit are made considerably easier with the GEA *Lplus* configuration software.

Time is money. This is also true for project planning of air-treatment technology. We have developed the GEA *Lplus* configuration software to enable selection and configuration of the best suitable central air handling unit as simply and rapidly as possible.

### Rapid and reliable planning

GEA air handling units have the advantage that all products can be adapted to individual requirements. The GEA *Lplus* configuration software helps you implement your desired unit in the shortest time possible. Configuration suggestions are made corresponding to your inputs. *Lplus* immediately calculates and provides component divisions, arrangement of the modules as well as weights and measures. Planning cannot be done any faster or more reliably! And you gain valuable time for other tasks.

Energy efficiency classes are today an important decision criterion. Therefore the software also specifies the appropriate energy efficiency class according to Eurovent and the AC manufacturer association for every solution. Furthermore, the forecast life cycle costs may be simply and comfortably calculated.

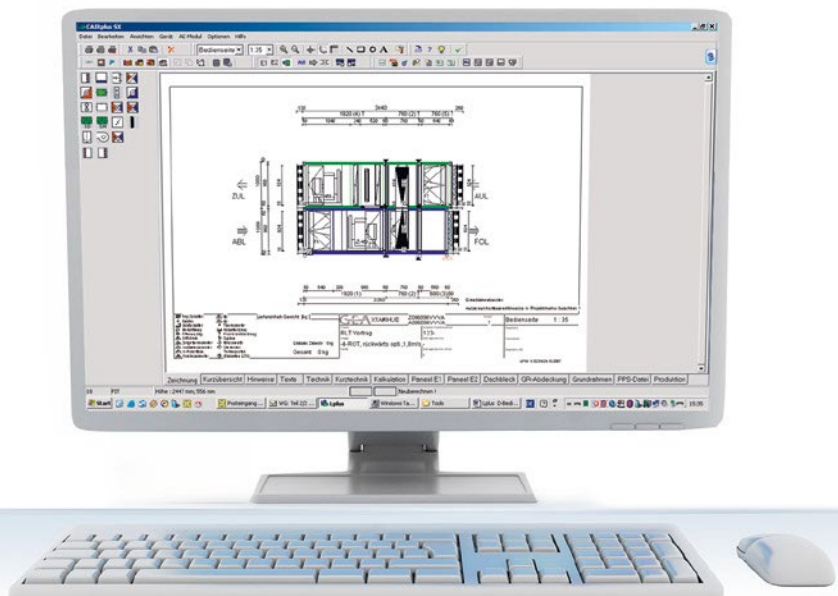

## LCC calculation

# Get all costs in advance

Apart from configuration and determination of the energy efficiency class, GEA *Lplus* software calculates the life cycle costs.

Increasingly more investors and operators are deciding for a certain solution dependent on the expected life cycle costs. The anticipated cost of the GEA Air Handling Units over the entire life cycle can be captured with the configuration software GEA *Lplus*.

You can compare units of different configurations with a representation of the actual cost structure over the complete life cycle. To make it easier to select the optimal features, you can compare several types of units on the user-friendly software interface and have the total costs and advantages of efficiency-increasing measures displayed. Planners can also employ such comparisons as an argumentation aid for investors.

The proportion of investment costs and operating costs is transparent and can be visualised. A simple and precise estimate can be made to calculate how rapidly this or that unit can be amortized.

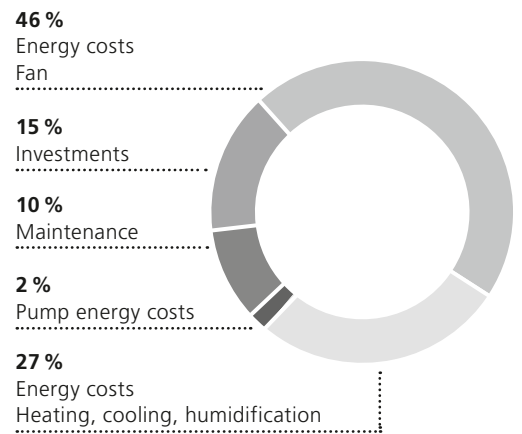

### Office building example

The calculations of the GEA *Lplus* software are based on the Eurovent recommendations for the determination of life cycle costs and take into account the important standards and regulations (DIN V18599-3 and VDI 2067-1).

## Life Cycle Costs

Investment costs	Energy costs	Maintenance	Disposal
<ul style="list-style-type: none"> <li>Planning</li> <li>Acquisition</li> <li>Installation</li> </ul>	<ul style="list-style-type: none"> <li>Electricity</li> <li>Heating / cooling</li> <li>Water</li> </ul>	<ul style="list-style-type: none"> <li>Cleaning / servicing</li> <li>Repair</li> </ul>	<ul style="list-style-type: none"> <li>Disassembly</li> <li>Recycling / disposal</li> </ul>

## Energetic certification

---

# Eurovent and AC Manufacturers Association



Eurovent assigns the energy efficiency label A to F, whereby units with the label A demonstrate the highest efficiency and no requirements are placed on units with efficiency class F.



The AC Manufacturers Association assigns the efficiency labels A+, A and B, while units that do not meet the requirements receive no label.

The configuration software GEA *Lplus* specifies the valid energy class for every GEA central air handling unit. This gives you additional certainty.

With attention on energy consumption, energy efficiency classes are an especially important decision criterion for deciding on a certain unit. Two certification programs – of Eurovent and the Manufacturers Association of Air Conditioning Units e. V. – evaluate the characteristics of units and assign appropriate energy efficiency classes. Additionally, the performance data of the component manufacturers undergo an approval by the German Technical Inspection Agencies (TÜV). The energy efficiency labels result from the examination, which permits a simple evaluation of the energy quality.

GEA air handling units mean high energy efficiency. The respective energy efficiency class of a certain unit according to Eurovent and the AC Manufacturers Association can be rapidly determined with the configuration software GEA *Lplus*.

GEA satisfies the requirements of the Eurovent Compliance Committee for Air Handling Units. The association expects that all members not only classify their air handling units with the Eurovent label, but also already give appropriate references in the associated configuration software. Calculation of the efficiency class with GEA *Lplus* provides you with binding pre-purchase proof of how well a unit economises on resources.

The software calculates the associated efficiency class for the configured device in real-time. The program considers five criteria in the background:

- Efficiency of the heat recovery
- Pressure loss of the heat recovery
- Air velocity in the unit
- Power consumption of the fan
- Climatic conditions of the location

The quality of the units as well as the rating data of the manufacturer measurements are additionally examined by Eurovent. The EN 13053 and EN 1886 directives determine various test criteria. These characteristics are regularly verified by independent testing facilities according to the Eurovent certification provisions.

**Casing characteristics (according to EN 1886 Standard)**

- Mechanical stability
- Air leakage rate
- Filter bypass leakage
- Thermal transmittance
- Thermal bridging factor
- Acoustical insulation

**Performance characteristics (according to EN 13053)**

- Air volume flow
- Available static pressure
- Power consumption
- Octave band in the air duct, sound power level
- Air-side sound power level
- Heating capacity
- Cooling capacity
- Heat recovery rate
- Waterside pressure loss

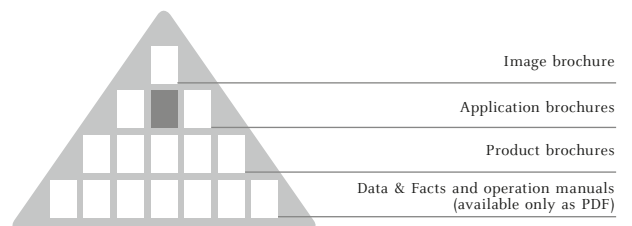

You are on this level of our documentation structure. You can order at no charge from the first 3 levels as printed copies, under: [info@gea-airtreatment.com](mailto:info@gea-airtreatment.com). You can download all brochures as PDF files from the following Internet site: [www.gea-airtreatment.com](http://www.gea-airtreatment.com).

## Customer proximity, sales structures

# Reachable always and everywhere!

- (AE)** GEA Air Treatment  
Middle East  
UAE-Dubai  
Tel. +971 / 4 / 887 3881
- (AT)** GEA Klimatechnik  
GmbH & Co KG  
A-4673 Gaspoltshofen  
Tel. +43 / 7735 / 8000-0
- (BA)** GEA Klimatechnik  
GmbH & Co KG  
RS-11070 Novi Beograd  
Tel. +381 / 11 / 3193955
- (BE)** GEA Happel Belgium N. V.  
B-1130 Brussels  
Tel. +32 / 2 / 2406161
- (BG)** EVISS Ltd.  
BG-7000 Rousse  
Tel. +359 / 82 / 81000
- (BY)** GEA Klimatechnik UAB  
LT-01141 Vilnius  
Tel. +370 / 5 / 2106060
- (CH)** ATC Klimatec Schweiz AG  
CH-3065 Bolligen  
Tel. +41 / 31 / 9171919
- (CZ)** GEA LVZ, a.s.  
CZ-46312 Liberec  
Tel. +420 / 48 / 5225-111
- (CZ)** GEA Klimatizace spol. s r.o.  
CZ-46312 Liberec  
Tel. +420 / 48 / 5225-303
- (DE)** GEA Happel  
Klimatechnik GmbH  
D-44625 Herne  
Tel. +49 / 2325 / 468-00
- (DE)** GEA Happel  
Wieland GmbH  
D-44625 Herne  
Tel. +49 / 2325 / 468-754
- (DE)** GEA Deichmann  
Umwelttechnik GmbH  
D-36179 Bebra  
Tel. +49 / 6622 / 504-0
- (DE)** GEA Delbag  
Lufttechnik GmbH  
D-44625 Herne  
Tel. +49 / 2325 / 468-700
- (DE)** GEA Delbag-Luftfilter  
Vertriebsgesellschaft mbH  
D-10709 Berlin  
Tel. +49 / 30 / 43592-3
- (EE)** GEA Klimatechnik UAB  
LT-01141 Vilnius  
Tel. +370 / 5 / 2106060
- (ES)** GEA Air Treatment  
Marketing Services Int.  
GmbH – oficina España  
ES-28028 Madrid  
Tel. +34 / 91 / 3837701
- (FI)** OY TEKNOCALOR AB  
FIN-01300 Vantaa  
Tel. +358 / 10 / 8201100
- (FR)** GEA Delbag  
Filtration de l'air  
F-77450 Montry  
Tel. +33 / 1 / 60043355
- (FR)** GEA Happel France sarl  
F-59436 Roncq Cedex  
Tel. +33 / 3 / 20689020
- (GB)** GEA Denco Ltd.  
UK-HR4 8DS Hereford  
Tel. +44 / 1432 / 277 277
- (HR)** GEA Klima-rashladna  
tehnika d.o.o.  
HR-10000 Zagreb  
Tel. +385 / 1 / 6064900
- (HU)** GEA Klimatechnika Kft  
H-1037 Budapest  
Tel. +36 / 1 / 4393200
- (IE)** Aspect Environmental Ltd.  
Ardee, Co. Louth Ireland  
Tel. +353 / 41 / 6858983
- (IS)** Rafn Jensson  
IS-110 Reykjavik  
Tel. +354 / 56 / 780-30
- (LT)** GEA Klimatechnik UAB  
LT-01141 Vilnius  
Tel. +370 / 5 / 2106060
- (LU)** GEA Happel Luxembourg  
L-4940 Bascharage  
Tel. +352 / 26 / 502970
- (LV)** GEA Klimatechnik UAB  
LT-01141 Vilnius  
Tel. +370 / 5 / 2106060
- (ME)** GEA Klimatechnik  
GmbH & Co KG  
RS-110 70 Novi Beograd  
Tel. +381 / 11 / 3193955
- (NL)** GEA Happel Nederland B.V.  
NL-2909 LL  
Capelle a/d IJssel  
Tel. +31 / 10 / 2350606
- (NO)** GEA Klimaprodukter AS  
N-0484 Oslo  
Tel. +47 / 220 / 27990
- (PL)** GEA Klimatyzacja sp.z.o.o  
PL-53-609 Wrocław  
Tel. +48 / 71 / 3565866
- (PT)** Nónio, Lda.  
P-1269-090 Lisboa  
Tel. +351 / 21 / 3826160
- (RO)** GEA Klimatechnik s.r.l.  
RO-300222 Timisoara  
Tel. +40 / 356 / 423703
- (RU)** GEA Klimatechnik  
GmbH & Co KG  
RU-105094 Moskva  
Tel. +7 / 495 / 9566674
- (SE)** GEA EXOS Ventilation AB  
S-74528 Enköping  
Tel. +46 / 171 / 85530
- (SI)** GEA Klimatizacijska  
Tehnika d.o.o.  
SI-1000 Ljubljana  
Tel. +386 / 1 / 2573850
- (SK)** GEA Klimatizácia s.r.o.  
SK-83104 Bratislava  
Tel. +421 / 7 / 44457917
- (RS)** GEA Klimatechnik  
GmbH & Co KG  
RS-11070 Novi Beograd  
Tel. +381 / 11 / 3193955
- (TR)** GEA ISISAN  
TR-80700  
Balmumcu Istanbul  
Tel. +90 / 212 / 2757171
- (UA)** GEA Ukraina t.o.v.  
UA-01135 Kyiv  
Tel. +38 / 044 / 4619356

The complete addresses are available on the  
Internet under: [www.gea-air-ecoznomy.com](http://www.gea-air-ecoznomy.com).



Air Eco<sub>2</sub>nomy®

[www.gea-air-ecoznomy.com](http://www.gea-air-ecoznomy.com)